

Technical Data:					
		Manual Separation	TEsepa Mini	TEsepa 18-30-60	TEsepa TE 60 A
Disc Finishing	TE 6 HD	○			
	TE 10 HD	○			
	TE 6 HDS	●	○	○	
	TE 10 HDS	●	○	○	
	TE 18	●	○	○	
	TE 30	●	○	○	
	TE 60	○		○	
	TE 60A				○
		Manual Separation	TVsepa Mini	TVsepa 18-30-60	
Troughvibrator	TV 30	○	○	○	
	TV 60	○	○	○	
	W 10	○			
	W 15	○		○	
	W 50	○		○	
	W 100	○		○	

Deburring - Rounding - Grinding - Smoothing - Polishing



Separation
of workpieces and abrasives

Manual Separation

The manual separation takes place in disc finishing machines by tilting the mixture of workpieces and abrasives or in trough vibrators by opening the side lock. Workpieces and abrasives are discharged into a manual screen box equipped with removable screens. By manual oscillation of the screen box, the abrasives fall into the collection container. The workpieces remain in the screen and can be removed. Screens can be easily and quickly changed. Manual separating units are available for all disc finishing and vibration equipment TE, TV and W.



TEsepa 18-30-60 and TVsepa

Workpieces and abrasives pass through the fitted bunker with gate to the screen deck. A speed variable unbalance motor with adjustable oscillating masses ensures good separation performance. Screens with height offset support the emptying of scooping parts. Undersized abrasives are separated on an underlying particle screen into a collection container. Bunkers, screens and particle screen can be easily changed.

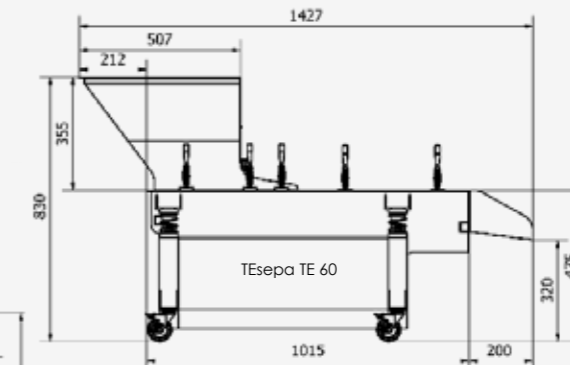

TEsepa Mini and TVsepa Mini

The TE(TV)sepa Mini facilitates the separation of workpieces and abrasives during the process and this avoids the necessity of manual labour. The TEsepa Mini is available as a top frame for several mass finishing machines. Sieves in different sizes are quick and easy to change. A subsequent installation of separation in existing machines is possible.

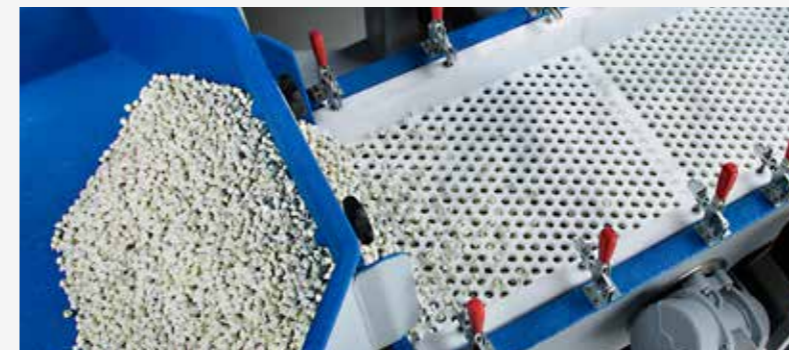
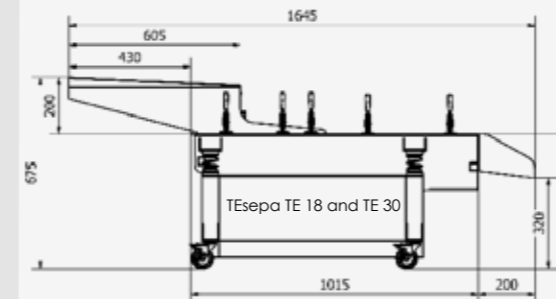

TEsepa TE 60 A

Work pieces and abrasives pass through the controlled dosing tray with bunker function to the screening machine. Two unbalance motors guarantee high separation performance. Screens with height offset support the emptying of scooping parts and are easily and quickly changed. Undersized abrasives are separated on an underlying particle screen into a collection container.